

Extended
Range



PREFIX Packaged Pressurisation Sets

AUTOMATIC MAKE-UP UNITS FOR SEALED HEATING AND
CHILLED WATER SYSTEMS



Prefix range of pressurisation equipment Microprocessor Single and twin pump units

Prefix Beta system

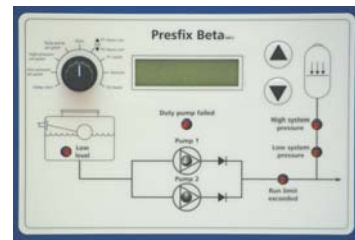

Display panel details.

Prefix Beta available as dual system units

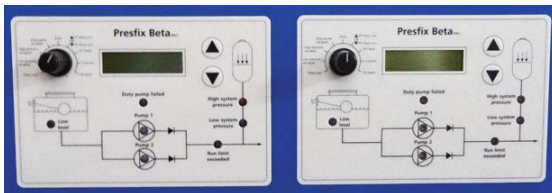

Dual display panel details.

Heating system

Chilled water system



Mini Prefix single and twin pump unit



Micro Prefix single and twin pump unit

Combined Heating and Chilled water systems

Sealed system benefits

In today's demanding environment nearly all heating and chilled water circulating systems are designed to operate in sealed networks.

The main benefits over previous systems which used feed and expansion tanks to accommodate expanded water are many, large volumes of water are no longer required to be stored at the top of the building. Expansion vessels can now be used in place of the storage tanks and these can be placed anywhere in the building, usually in the basement where the weight is not such a problem. The Feed and expansion tank being open to atmosphere allowed water to evaporate making unnecessary demands on this precious resource.

Sealed systems reduce corrosion to an absolute minimum by sealing the system content from atmosphere, and only adding fresh water to replace losses through leakage.

Sealed systems also offer the possibility of operating at higher temperatures if required (Max 120°C) which permits lower circulation rates, smaller pumps and reduced pipe work dimension with obvious cost savings.

Pressurisation system guide Low-Medium temperature typical layout

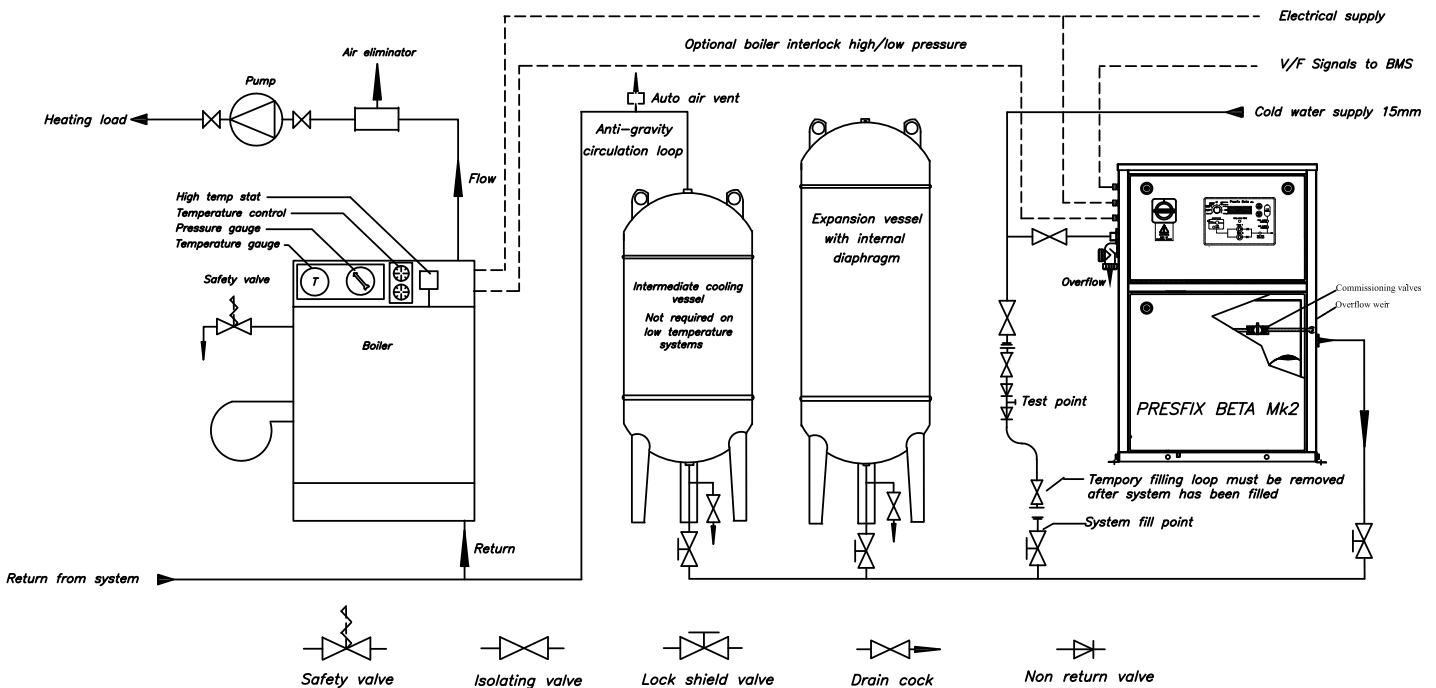

Prefix Beta dual unit

Prefix Beta dual pressurisation sets bring the benefits of managing two independent systems from a single unit. The unit contains two individual display screens so each system can be controlled and monitored separately providing both systems operate at the same fill pressure which should generally be the case as the fill pressure is based on the building static height.

All other set points can be independently set for each system

All Prefix Beta Dual system units are supplied as two pump sets and are available in three ranges, 2.8 bar, 5.5 bar and 8.0 bar fill pressures.

Each pump is available to both systems so each system has a duty and standby pump available to it. If one pump fails then the standby pump will be available to both systems.

All the control features and specification are the same as the standard two pump Prefix Beta details

Pressurisation dual system guide Low-Medium temperature typical layout for heating and chilled water systems

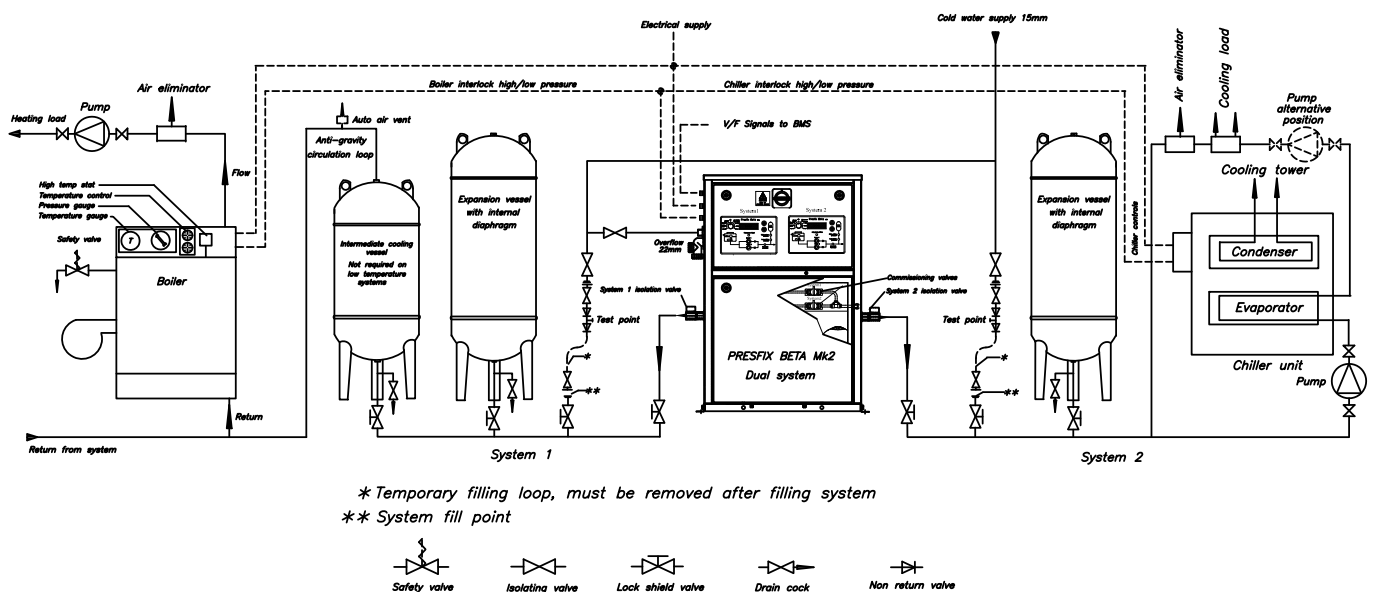

Application

Prefix pressurisation units are designed to replace water that has been lost through system leakage and to maintain the system design fill pressure in sealed heating and chilled water systems in accordance with BS7074 parts 1, 2 and 3.

Prefix units also provide safety circuits locking out the boiler / chiller in the advent of high/ low pressures occurring. Expanded water is accommodated in membrane vessel/s that are supplied separately and normally installed alongside the Prefix unit.

Prefix units are perfect for either domestic or industrial environments. Three levels of sophistication are offered along with two pressure ranges for the Mini Prefix and single range for Micro Prefix units.

All levels provide volt free contacts that can be used to interface with either a Business Management System or any other type of monitoring system.

Prefix units have flow limiting devices to help prevent plant rooms from flooding in the advent of system pipe/fitting failure.

Control features

Prefix Beta MK 2 microprocessor

- Mains door interlocked disconnect switch.
- Auto/Manual/Off selector switch.
- Back lit digital display.
- Control panel section IP 54.
- MCB protected motors.
- Simple set point adjustment.
- Parameter lock.
- Remote inhibit.
- Delay start.
- Exercise regime.
- Break tank low water monitoring.
- Transducer controlled.
- High/Low pressure contacts for boiler/chiller interlock.
- Anti-bounce internal vessel 2lt electronically assisted.
- Isolating valves on each pump.
- Hours run for each pump.

Additionally twin pump units have:

- Automatic duty pump rotation with omission of tripped or failed pumps.
- Duty pump fail with auto change over to stand by pump.

LED indicators for:

- Pump run each pump.
- Pump trip each pump.
- Low pressure.
- High pressure.
- Duty pump failed.
- Excessive run time.
- Break tank Low water.
- Back lit display provides indication of power on.

Volt free contact for:

- Pump run each pump.
- Pump trip each pump.
- High pressure.
- Low pressure.
- Excessive run time.
- Break tank low level.
- Duty pump failed (two pump units).

Mini Prefix and Micro Prefix

- Switched mains isolator with neon indicators.
- Fuse protected motors.
- Auto/Manual/Off selected through display panel
- High contrast digital display.
- Transducer controlled.
- Simple set point adjustment.
- Parameter lock.
- Delay start.
- Exercise regime.
- Break tank low water monitoring.
- Hours run each pump.
- Isolating valves on each pump, Mini Prefix only.
- High/Low pressure switch for boiler/ chiller interlock.

Additionally twin pump units have:

- Automatic duty pump rotation.
- Duty pump fail with lockout and auto change over to standby pump.

Micro Prefix twin pump units

- Parallel operation

Neon indicator for :

- Power on.
- All other faults are shown scrolling through the digital display.

Volt free contact for:

- Common fault.
- High pressure.
- Low pressure.
- Boiler interlock Low/High pressure.

Expansion vessel sizing

Vessel sizing calculations should be carried out in accordance with BS7074.

Details of calculating method can be obtained from Lowara UK or we will be happy to calculate the required vessel size for you if you can provide the following data.

1. Static height above pressurisation unit.
2. System content (volume) if unknown boiler power (Kw) can be used to estimate system content.
3. Flow and return temperatures.
4. Glycol content (%).
5. Final working pressure.

Applied standards

- Machinery Safety Directive. 2006/42/EC.
- UK Health and Safety Requirements. 2008No.1597.
- Water supply (water fittings) regulations.1999.
- Electromagnetic compatibility (EMC) Directive 2014/30/EU.
- Code of practice for heating and chilled water systems. BS7074 Parts 1, 2 and 3.

Specification

All units are enclosed and manufactured from powder coated steel.

Pumps

Pumps are horizontal peripheral type with bronze/ composite body and impeller and are fitted with self adjusting mechanical seals for the Prefix Beta and Mini Prefix.

Micro Prefix units have oscillating pumps with built in non return valves. All metal parts in contact with water are Stainless Steel.

Coated steel

The Prefix Beta has individual sections for the electrical controls and the hydraulic equipment. The Mini and Micro Prefix have the electrical controls in a plastic control panel mounted at the top of the main steel housing. These units are suitable for either floor or wall mounting.

Break tank Prefix Beta and Mini Prefix

Manufactured from Polyethylene with an 18lt active capacity complete with weir and clip tight lid. Ball valve 15mm to BS1212 part 2 constructed to give a type AB air gap in accordance with the water regulations 1999.

Overflow 22mm (plastic).

Micro Prefix has a Stainless Steel tank 3lt active capacity tank fitted with WRAS approved ball valve and type AB air gap in accordance with the water regulations 1999.

Overflow 22mm (plastic).

Pipework

Nylon 4-10mm.

Internal vessel (Prefix Beta only)

2Lt steel construction complying with BS4814.

Electrical specification

Supply voltage: 230V 50Hz 1Ph

For other supply voltages contact our sales office.

Volt free contact rating: 50V AC 3A

Standard range

Prefix Beta MK 2

Type	Maximum fill pressure	Single pump Unit	Twin pump Unit	Kg	Motor Size	Input Current	Pre-fuse
Prefix Beta 128	2.8 bar	UKBETA100HL28/A		36Kg	0.37kW	2.5A	10A
Prefix Beta 228	2.8 bar		UKBETA200HL28/A	45Kg	0.37kW	2.5A	10A
Prefix Beta 228 Dual System	2.8 bar		UKBETA200DS28/A	45Kg	0.37kW	2.5A	10A
Prefix Beta 155	5.5 bar	UKBETA100HL55/A		37Kg	0.37kW	3.2A	10A
Prefix Beta 255	5.5 bar		UKBETA200HL55/A	46Kg	0.37kW	3.2A	10A
Prefix Beta 255 Dual System	5.5 bar		UKBETA200DS55/A	46Kg	0.37kW	3.2A	10A
Prefix Beta 180	8.0 bar	UKBETA100HL80/A		39Kg	0.75kW	6A	10A
Prefix Beta 280	8.0 bar		UKBETA200HL80/A	50Kg	0.75kW	6A	10A
Prefix Beta 280 Dual System	8.0 bar		UKBETA200DS80/A	52Kg	0.75kW	6A	10A

Mini Prefix

Type	Maximum fill pressure	Single pump Unit	Twin pump Unit	Kg	Motor Size	Input Current	Pre-fuse
Mini Prefix 128	2.8 bar	UKMIBE100HL28		28Kg	0.37kW	2.5A	10A
Mini Prefix 228	2.8 bar		UKMIBE200HL28	37Kg	0.37kW	2.5A	10A
Mini Prefix 155	5.5 bar	UKMIBE100HL55		29Kg	0.37kW	3.2A	10A
Mini Prefix 255	5.5 bar		UKMIBE200HL55	38Kg	0.37kW	3.2A	10A

Micro Prefix

Type	Maximum fill pressure	Single pump Unit	Twin pump Unit	Kg	Motor Size	Input Current	Pre-fuse
Micro Prefix 140	4.0 bar	UKMICRO100HL40		8.5Kg	48 W	1A	5A
Micro Prefix 240	4.0 bar		UKMICRO200HL40	8.7Kg	48 W	1A	5A

The Prefix Beta and Mini Prefix units contain high quality bronze or Ryton pumps to help eliminate seizure due to infrequent operation.

Micro Prefix units are fitted with Oscillating pumps fitted with NBR seals.

All the above units include High/Low pressure contacts to interlock with the boiler/chiller.

Other options include specialised systems for large volume storage.

Please contact our sales office for details Tel. 01297 630230. Fax. 01297 630270. E-mail lowaraukenquiries@xyleminc.com

Dimension specifications

Prefix Beta MK 2 single & twin pump unit 2.8-5.5-8.0 bar

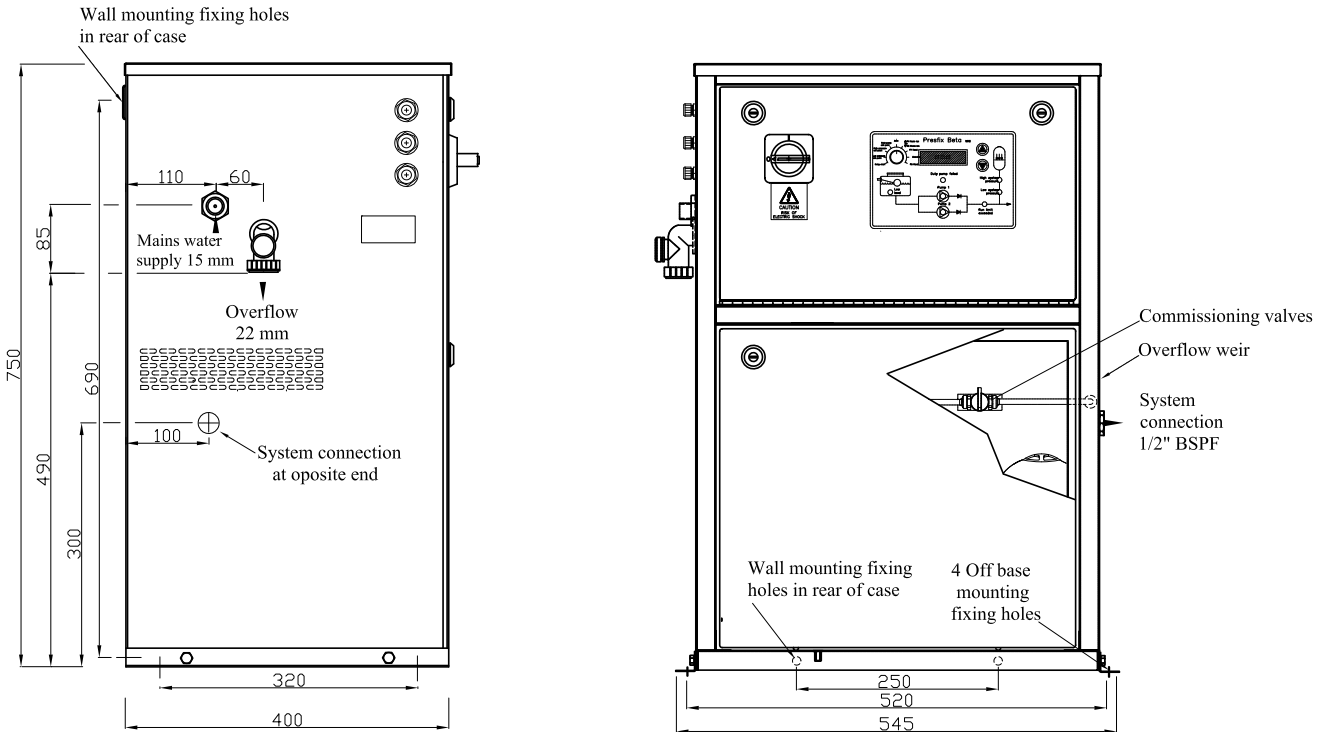

Prefix Beta MK 2 dual system twin pump unit 2.8-5.5-8.0 bar

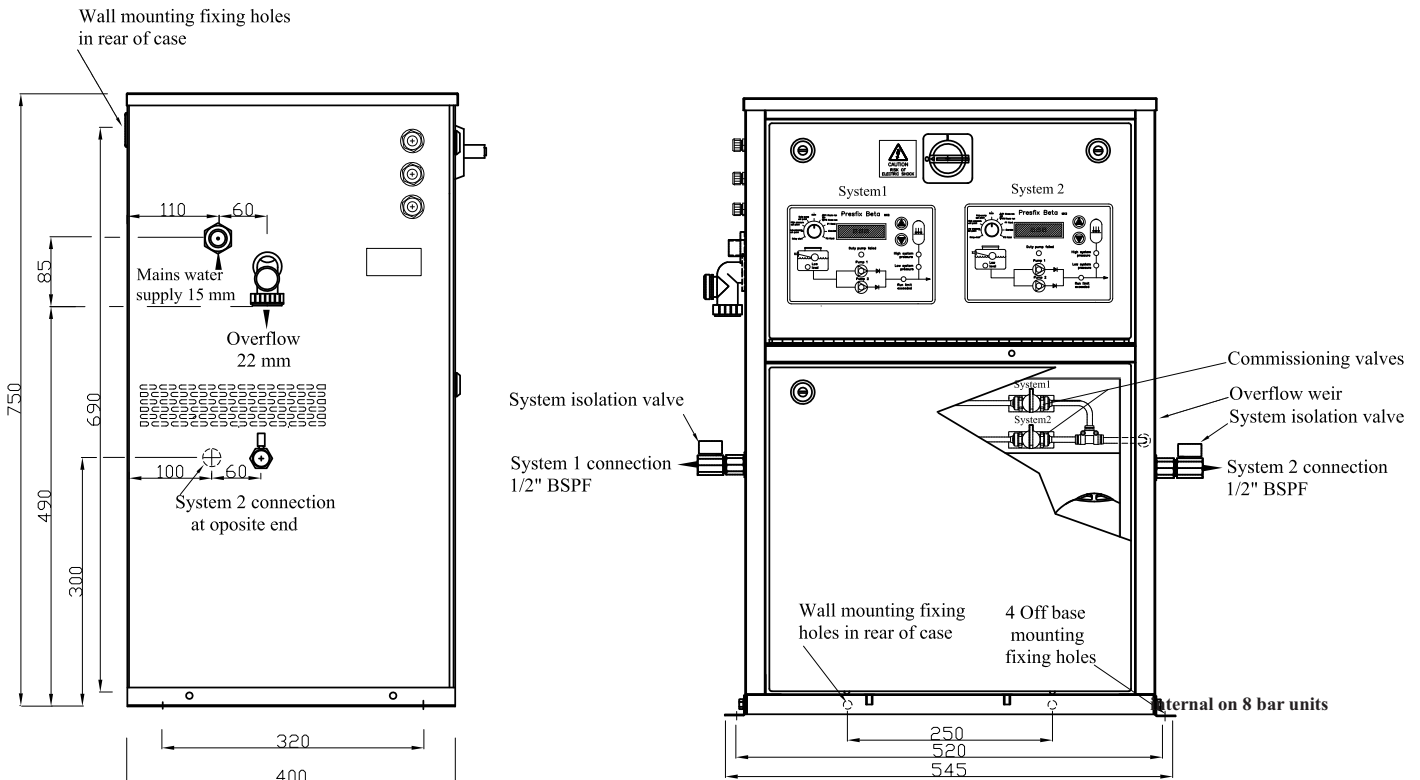

All dimensions in mm

Mini Prefix single and twin pump unit 2.8-5.5 bar

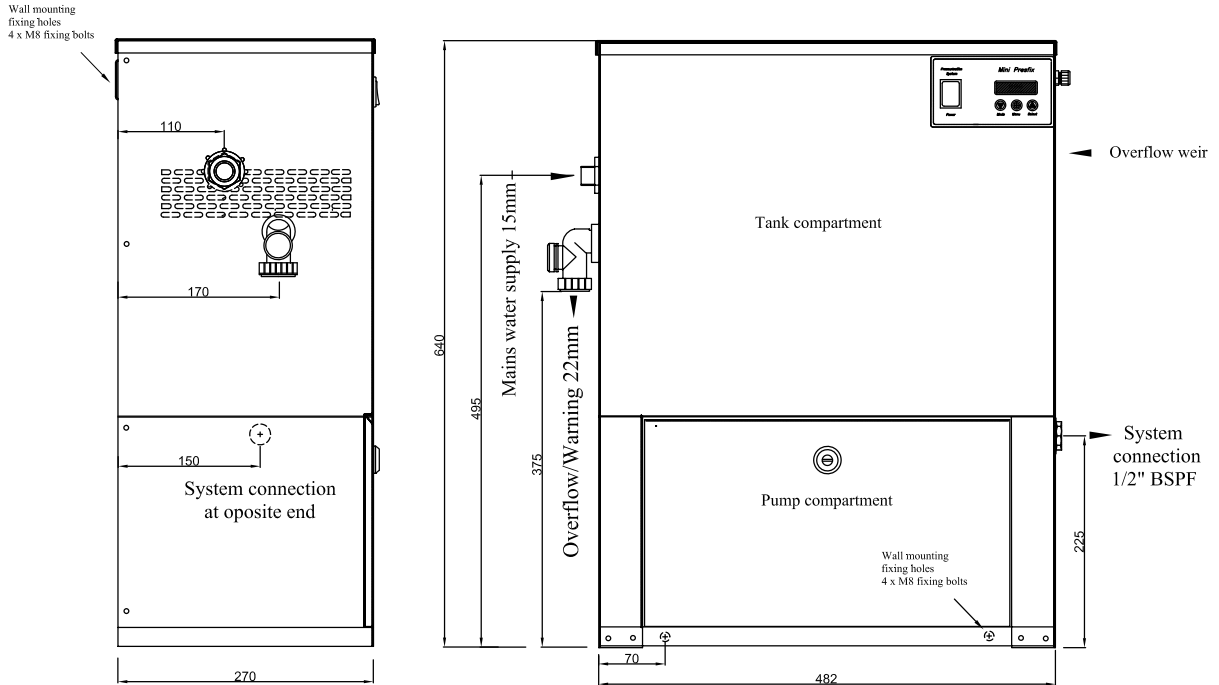

MicroPrefix single and twin pump units 2.5-4.5bar

AB air gap suitable for liquid upto category 5

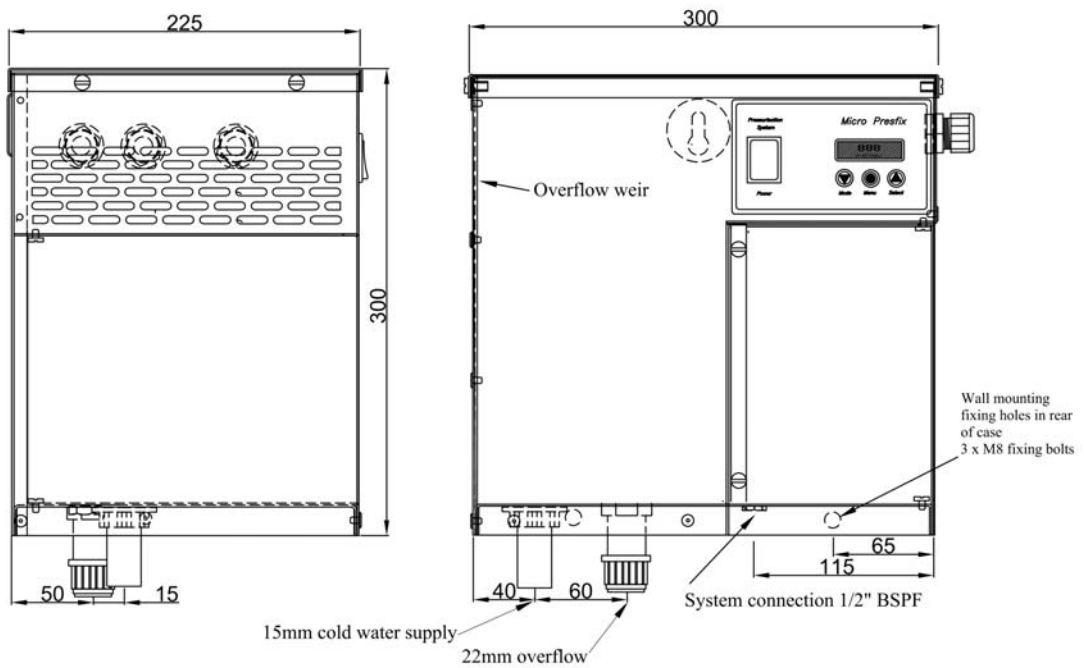

Standard vessel details

The pressure vessel is designed to provide a storage facility and pressure reservoir for water. Common uses are in water booster sets, heating pressurisation and fill sets.

Vessel's are supplied pre-charged, but the pressure may require adjustment to suit the site conditions.

This adjustment must be made with the vessel isolated from the system, and before filling with water.

All pressure vessels should be installed with an isolating valve and drain cock.

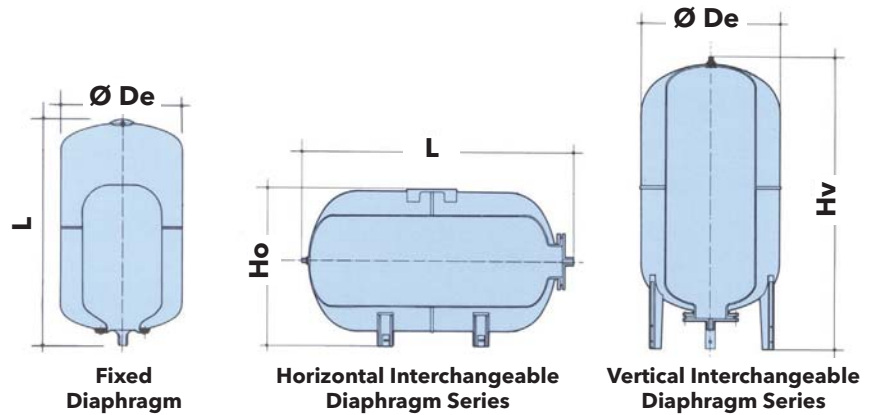

Vessel Type	Capacity in litres	Connection Size	Maximum Pressure Bar	Max liquid temperature	Ho mm	L mm	Ø De mm	Hv mm	Vessel Colour	Manufacturer	WRAS Approved
2 LV ♦	2	½"	10	70°C	-	196	140	-	Blue	Zilmet	✓
5 LV	5	¾"	10	70°C	-	316	160	-	Blue	Zilmet	✓
8 LV ♦	8	¾"	10	70°C	-	326	200	-	Blue	Zilmet	✓
18 LV	18	1"	10	70°C	-	395	270	-	Blue	Zilmet	✓
24 LH/LV ♦	24	1"	10	70°C	-	485	270	-	Blue	Zilmet	✓
24 LV	24	1"	10	90°C	-	447	290	-	White	GWS	✓
60 LH/LV	60	1"	10	70°C	410	690	380	880	Blue	Zilmet	✓
60 LH/LV	60	1"	10	90°C	424	530	389	620	White	GWS	✓
80 LH/LV	80	1"	10	70°C	480	690	450	850	Blue	Zilmet	✓
80 LH/LV	80	1"	10	90°C	424	726	389	815	White	GWS	✓
100 LH/LV	100	1"	10	70°C	480	797	450	950	Blue	Zilmet	✓
100 LH/LV	100	1"	10	90°C	475	720	430	804	White	GWS	✓
200 LH/LV	200	1½"	10	70°C	580	1075	550	1285	Blue	Zilmet	✓
200 LV	200	1¼"	10	90°C	-	-	534	1041	White	GWS	✓
300 LH/LV	300	1½"	10	70°C	660	1230	630	1415	Blue	Zilmet	✓
300 LV	300	1¼"	10	90°C	-	-	534	1511	White	GWS	✓
450 LV	450	1¼"	10	90°C	-	-	661	1539	White	GWS	✓
500 LV	500	1½"	10	70°C	-	-	750	1610	Blue	Zilmet	✓
750 LV	750	2"	10	90°C	-	-	750	1950	White	GWS	✓
1000 LV	1000	2"	10	90°C	-	-	800	2180	White	GWS	✓
1500 LV	1500	2"	10	90°C	-	-	960	2380	White	GWS	
2000 LV	2000	2"	10	90°C	-	-	1100	2520	White	GWS	
3000 LV	3000	2½"	10	90°C	-	-	1200	2800	White	GWS	
4000 LV	4000	3"	10	90°C	-	-	1450	3100	White	GWS	
5000 LV	5000	3"	10	90°C	-	-	1450	3720	White	GWS	
24 LV	24	1"	16	90°C	-	-	290	447	White	GWS	✓
100 LV	100	1"	16	90°C	-	-	431	804	White	GWS	✓
200 LV	200	1¼"	16	90°C	-	-	590	1120	White	GWS	
300 LV	300	1¼"	16	90°C	-	-	640	1230	White	GWS	
500 LV	500	1¼"	16	90°C	-	-	750	1550	White	GWS	
750 LV	750	2"	16	90°C	-	-	750	1950	White	GWS	
1000 LV	1000	2"	16	90°C	-	-	800	2180	White	GWS	
DE 8	8	¾"	25	70°C	-	-	206	320	Blue	Reflex	
DE 80	80	DN 50	25	70°C	-	-	450	925	Blue	Reflex	
DE 120	120	DN 50	25	70°C	-	-	450	1235	Blue	Reflex	
DE 180	180	DN 50	25	70°C	-	-	450	1515	Blue	Reflex	
DE 300	300	DN 50	25	70°C	-	-	750	1275	Blue	Reflex	
DE 400	400	DN 50	25	70°C	-	-	750	1395	Blue	Reflex	
DE 600	600	DN 50	25	70°C	-	-	750	1860	Blue	Reflex	
DE 800	800	DN 50	25	70°C	-	-	750	2260	Blue	Reflex	
DE 1000	1000	DN 50	25	70°C	-	-	750	2760	Blue	Reflex	

♦ Also available in Stainless Steel.



XLC-in-house training, seminars and new product launches

With our Xylem Learning Centre we provide a learning environment that promotes the transfer of new skills and knowledge to the work setting through both classroom and technology-based instruction. Our training team comprises experienced individuals throughout the organisation who have expert knowledge of our products, markets and services. We are available to assist you and your organisation to meet your training needs.

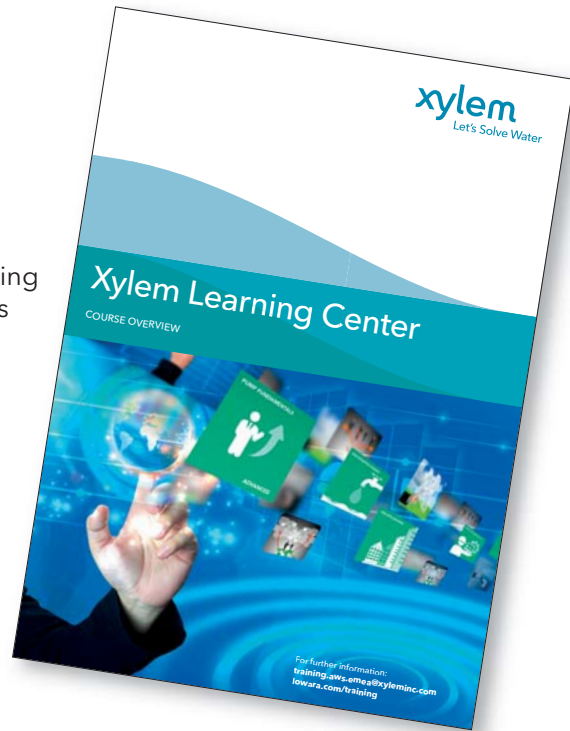

There are people who do, and people who teach. We do both!

Xylem provides complimentary training in selection and use of all Xylem products at its training centers in Europe. The courses are designed to be practical as well as theoretical, preparing delegates with skills to size and specify the correct pumps and related technologies for a range of applications and systems.

Courses and features.

	Manufactured facilities and domestic applications	Variable Speed Drive	HVAC drives	Pumping equipment selection
Pump basic training course	✓	✓		✓
Pump advanced training course	✓	✓	✓	✓
Commercial Building Services product & application course	✓		✓	✓
Consultant's training on pumping equipment	✓		✓	✓
Heating basic: covering basic hydronic theory and system calculation	✓		✓	✓
Heating advanced: advanced system design	✓		✓	✓
Air Conditioning essential: basic hydronic theory and small/medium chiller systems	✓		✓	✓
Air Conditioning advanced: large chiller systems	✓		✓	✓
Industrial pump product & application course	✓	✓	✓	✓
Drives and monitoring, advanced course	✓	✓	✓	✓
Wastewater and sewage course	✓	✓	✓	✓
Residential course	✓			✓
Environmental and legislation course	✓	✓	✓	✓
After sales service training	✓			✓
Food and beverage training	✓			✓

Xylem/Lowara CPD presentations CIBSE accredited courses

One or two hour CPD seminars, at the clients premises, half and full day training can be arranged at company HQ in Axminster, Devon or at any location in the UK.

All courses cover the pumps, systems and variable speed drives. Xylem also offer HVAC application training, all are taught by experts in the field and comprehensive course notes are provided.

For up to date news on products, services and a complete calendar for training events and exhibitions please visit our web site www.lowara.co.uk

Xylem | 'zīləm |

- 1) The tissue in plants that brings water upward from the roots;
- 2) a leading global water technology company.

We're a global team unified in a common purpose: creating advanced technology solutions to the world's water challenges. Developing new technologies that will improve the way water is used, conserved, and re-used in the future is central to our work. Our products and services move, treat, analyze, monitor and return water to the environment, in public utility, industrial, residential and commercial building services, and agricultural settings. With its October 2016 acquisition of Sensus, Xylem added smart metering, network technologies and advanced data analytics for water, gas and electric utilities to its portfolio of solutions. In more than 150 countries, we have strong, long-standing relationships with customers who know us for our powerful combination of leading product brands and applications expertise with a strong focus on developing comprehensive, sustainable solutions.

For more information on how Xylem can help you, go to www.xylem.com



Xylem Water Solutions UK Limited

Millwey Rise Industrial Estate
Axminster, Devon EX13 5HU - UK
Tel: 01297 630230
Fax: 01297 630270
Email: lowaraukenquiries@xylem.com
www.lowara.co.uk

Xylem Water Solutions Ireland Limited

50 Broomhill Close
Airton Road
Tallaght - Dublin 24
Tel: (+353) 01 452 4444
Fax: (+353) 01 452 4795
Email: flygtlRL@xylem.com
www.xylemwatersolutions.com/ie

Lowara is a trademark of Xylem Inc. or one of its subsidiaries.
© 2017 Xylem, Inc.

Xylem Water Solutions UK Limited reserve the right to make modifications without prior notice.

Code UKLIT0013 P03/17

